

Efficiency Improvement through the Life-cycle Process of Curtain Wall Construction

Yea-Sang Kim

Professor, Sungkyunkwan University, Seoul, Korea

Soon Oh Jung

Assistant Professor, Kyungbok Position College, Pochon, Korea

Chang Duk Kim

Professor, Kwangwoon University, Seoul, Korea

Jae Youl Chun

Associate Professor, Dankook University, Seoul, Korea

Abstract

The purpose of this study is to improve efficiency of the curtain wall construction through its life-cycle process by finding wastes and problems in the existing process and removing them. In order to do this, the study first identifies detailed activities in each phase of the curtain wall construction process: architectural design, curtain wall engineering design, off-site manufacturing of curtain wall units, on-site construction and maintenance. Secondly, reasons and sources of such wastes and problems are found and listed according to the Muda system, which was developed by Toyota. Thirdly, the relative importance of each reason and source is evaluated by the Analytic Hierarchy Process (AHP) method based on experts' opinion. Finally, the results indicate the reasons for and source of wastes and problems, and in which phases it is more critical to improve the efficiency of the overall curtain wall construction process.

Keywords

Curtain Wall Construction, Efficiency, Life-cycle Process, Muda system, AHP method

1. Introduction

The life-cycle of a construction project includes planning, design, construction, operation and maintenance phases. However, it is a common perception that time, cost, quality and overall efficiency are matters of the construction phase, which means that influences of many factors in other phases are often overlooked. Curtain wall construction in a building project is a good example where whole process over all phases should be considered to improve project efficiency. Not only the phases mentioned above, but also the engineering design and off-site manufacturing phases particularly need to be controlled and managed efficiently.

Therefore, the purpose of this study is to improve the efficiency of the curtain wall construction process through its life-cycle, especially focusing on unit type curtain walls. To do this, two different approaches can be considered: one is to find wastes and problems in the existing processes and remove them, and the other is to apply innovative methods and processes to it. This study focuses on the former.

First, the study identifies detailed activities in each phase of the curtain wall construction process, which consists of architectural design, curtain wall engineering design, off-site manufacturing of curtain wall units, on-site construction and maintenance phases. Secondly, reasons and sources of such wastes and problems are found and listed according to the Muda system, which was developed by Toyota. Thirdly, the relative importance of each reason and source is evaluated by the Analytic Hierarchy Process (AHP) method based on experts' opinion. Finally, the results suggest the reasons for and source of wastes and problems, and in which phases it is more critical to improve the efficiency of the overall curtain wall construction process.

2. Definition and Analysis of Efficiency in Curtain Wall Construction

2.1 Definition of Efficiency

Efficiency has been defined somewhat differently by different scholars since Koopmans and Debreu (1951). Sometimes, it is understood to have the same meaning as productivity, but more frequently it means an efficient usage of inputs or methods in a certain production system. To improve efficiency, there may be two approaches: one is to apply better production skills or innovative technology to the existing production process, and the other is to remove inefficient factors in it. Since there remain problems in the former method even though new skills or technology are adopted, it seems more effective to find, and remove those problems. Here the problem can be defined as waste, which means certain activities not adding value to the product. The more entities that are involved in the production process, the more wastes that can be found. It is also true in curtain wall construction, which consists of many different phases, where many different entities work independently or cooperatively. For example, lack of proper information sharing or communication provokes delays or even reworks. If such problems along the life-cycle of curtain wall construction are removed, overall process efficiency can be improved.

2.2 Efficiency Analysis Tool: Toyota Production System's Muda

Muda, meaning waste in Japanese, is one of the most effective tools developed by Toyota to examine and evaluate the wastes and problems in the production system. According to this approach, wastes come from seven categories of problems: unnecessary motion, waiting, overproduction, defects, excessive transportation, unnecessary inventory, and inappropriate processing (Freire and Alarcon, 2002). In this study, the concepts of these seven categories are applied to the curtain wall construction process to find waste factors in each phase. For example, overproduction in the curtain wall design phase can be producing excessive drawings. Application of the concept and identification of the waste factors in each category are verified or adjusted, if necessary, by the experts in each phase. Table 1 shows example problems and waste factors in the category of overproduction for each phase.

Table 1: Problems and Wastes Related to Overproduction in Curtain Wall Construction

Phase	Problems	Wastes
Architectural Design	Excessive drawings	unclear client's design requirements / too many alternatives required / too many details / details unnecessary in architectural design
Curtain Wall Engineering	Excessive drawings	unclear client's design requirements / too many alternatives required / too many details / too many mock-up tests
Manufacturing	Excessive unit production	improper manufacturing plan / production not considering on-site installation schedule / reproduction due to defects
Construction	Excessive unit delivery	excessive orders / delays due to excessive works other than curtain wall work / improper scheduling of on-site work
Maintenance	Excessive maintenance work	Excessive maintenance work

2.3 As-is Modelling of the Curtain Wall Construction Process

The next step is to evaluate existing curtain wall construction processes in terms of problems and wastes, namely efficiency or inefficiency. This study focuses on unit type curtain walls and its as-is model has been constructed using the IDEF0 methodology through indepth interviews with experts.

The whole process, which is level 1 in the IDEF0 model, consists of four major activities as shown in Figure 1 (Chin, 2004). In the lower level, the design phase is broken down into architectural design, curtain wall engineering, and mock-up test; the manufacturing phase, into extruding, painting, assembly, and glazing; the construction phase, into transportation, hosting, and installation. The model also identifies the entities involved, various constraints and information as input or output regarding each activity.

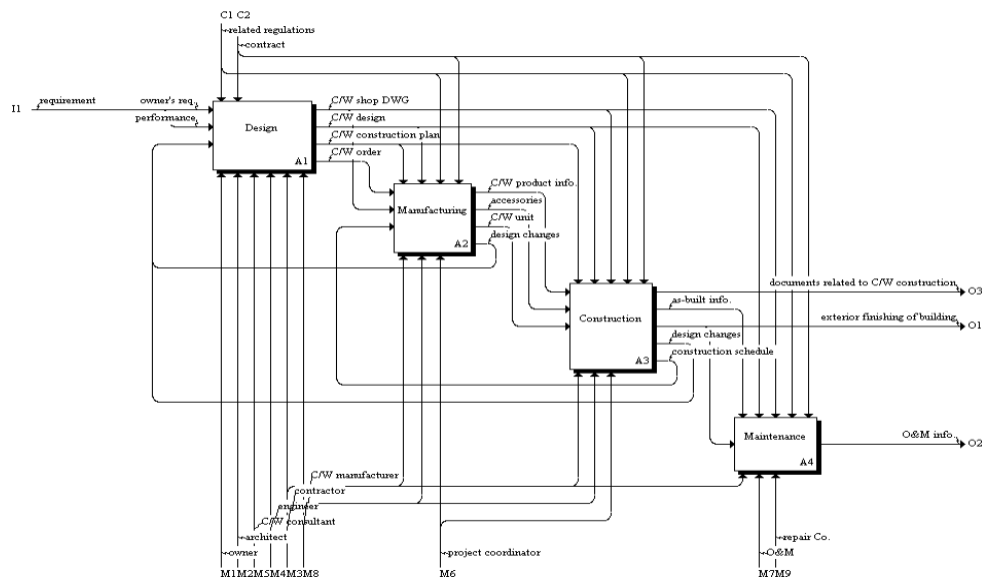

Figure 1: Curtain Wall Construction Process Model – Level 1

3. Evaluation of Problems, Wastes and Findings

3.1 AHP Analysis of Problems and Wastes

We want to know how significantly each waste factor in each category or phase is influencing the efficiency of the curtain wall construction process. The Analytical hierarchy process (AHP) methodology was used as

an analysis tool to evaluate problems and wastes. Questionnaires were designed and distributed to the experts to determine the influence of each problem or factor on efficiency based on the as-is model. Eight or nine experts respectively from architectural design offices, curtain wall engineering offices, curtain wall specialty contractors, and general contractors answered the questionnaire. Figure 2 shows the structure or hierarchy of the questions and data analysis. For example, the first analysis, which covers the first and the second levels, is to determine the importance level of each phase for overall curtain wall construction efficiency. The second analysis, which covers the second and the third levels, is to determine how serious each problem category is in each phase. Finally, in the fifth analysis, the impact of each waste factor on the whole process is evaluated based on the previous analysis results.

3.2 Summary of Findings

Through the AHP analysis, the more serious and critical problems or wastes were determined. This section gives a summary of the findings and gives brief recommendations.

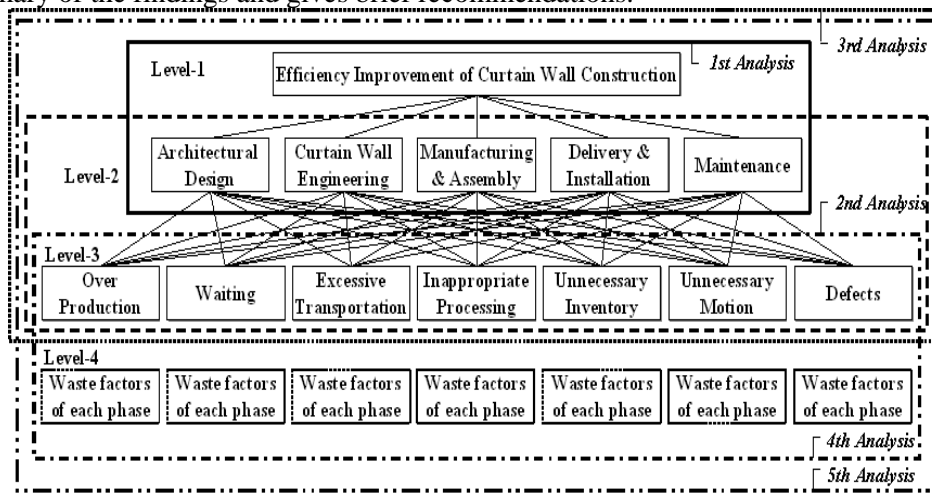

Figure 2: Hierarchy of AHP Analysis on Curtain Wall Construction

3.2.1 Architectural design phase

The analysis results revealed the architectural design phase was the most critical for the overall efficiency. Especially, delays in client’s decisions or approvals, lack of architect’s knowledge in curtain wall design and lack of communication between client and architect made this phase inefficient. Such problems can be improved if curtain wall consultants or contractors are involved earlier in this phase. Effective communication tools and methods between client and architect, or even consultants, must be considered for better information flow.

3.2.2 Curtain wall engineering phase

The most serious wastes in this phase were the lack of consideration of site conditions or constructability, and frequent design changes in architectural drawings. These wastes or inefficiencies come from insufficient or ineffective communication among the entities, including clients, architects and engineers. The role of architects for coordination is more important in this phase, and curtain wall engineering companies with construction experience can provide better inputs.

3.2.3 Curtain unit production and assembly phase

This phase is second only to the architectural design phase in terms of seriousness. Typical wastes were: low productivity in producing different types of units for every different project, cost increases and schedule delays due to lack of design standardization, and delivery problems due to outsourcing production.

3.2.4 Curtain unit installation phase

The wastes in this phase were mostly related to improper unit transportation and hoisting plans and insufficient communication between curtain wall suppliers and contractors. As a result, delivery delays, improper positioning and reloading of units, and interruption with other works occurred frequently leading to inefficiency. Therefore, more detailed construction plans including site layout must be set up ahead of time. Tools and methods for timely communication must be considered as well.

3.2.5 Maintenance phase

The maintenance phase has fewer problems and wastes than the previous phases. However, waste factors, such as curtain wall design, enables better maintenance; repair or reinstallation must be considered in an earlier phase of architectural or engineering design. Therefore, there should be a feedback mechanism in which data and information in the maintenance phase can be used as input to earlier phases.

4. Conclusion

Curtain wall construction in a building project is one of the most critical works in terms of project cost and schedule. Improvement of its efficiency will contribute to the success of the project, but it must be approached with respect to the whole life-cycle process, including, design, engineering, manufacturing, installation and maintenance. In this study, based on the assumption that efficiency can be improved by removing inefficiency, problems and wastes factors were investigated using the Muda system and analyzed using the AHP methodology through in depth expert interviews. An as-is model for unit type curtain wall construction process was constructed as well.

As a result, it was found that architectural design phase was the most critical problem area, influencing efficiency in the next phases. In addition, waste factors in every phase were analyzed and compared to determine the most critical one for better efficiency improvement. However, the results show that common problems and wastes came from improper or insufficient communication among the entities involved in the whole process. It verifies that efficiency improvement of the curtain wall construction process is not solely a matter of the construction phase but a matter of the whole life-cycle process.

5. References

- Koopman, T. C. (1951), "An Analysis of Production as an Efficient Combination of Activities," John Wiley and Sons, Inc.
- Freire, J. and Alarcon, L. F. (2002) "Achieving Lean Design Process: Improvement Methodology," *Journal of Construction Engineering and Management*
- Chin, S., Yoon, S., and Kim, Y. (2004), "An Analysis of the Life-Cycle Curtain Wall Process Through Supply Chain Management," *Proceedings of International Group of Lean Construction*, Copenhagen, Denmark.