

Role of Construction in the Poor Performance of Deck Panel Bridges

Atiq Alvi

Senior Structural Engineer, Parsons Brinkerhoff, Tampa, Florida, USA

Ivan Gualtero

Structural Engineer, Ayres Associates, Tampa, Florida, USA

Niranjan Pai

Structural Engineer, Bridge Concepts, Tampa, Florida, USA

Rajan Sen

Professor, University of South Florida, Tampa, Florida, USA

Gray Mullins

Associate Professor, University of South Florida, Tampa, Florida, USA

Abstract

Precast deck panel bridges were first used in the construction of highway bridges in Illinois in the early 1950's. This type of construction offers significant economies; the stay-in-place (SIP) panel combined with a cast-in-place (CIP) topping can considerably reduce construction time as field forming is only needed for the exterior girder overhangs. Florida has approximately 200 precast deck panel bridges. Despite successful performance in other states, precast deck panel bridges have a long history of premature deterioration in Florida that has led to excessive maintenance and impacts to the traveling public. A program is underway to systematically replace selected deck panel bridges. During the replacement of these bridges the opportunity was taken to conduct on-site investigations on bridges that were in different states of disrepair. This paper provides an overview of the problems and a brief description of the on-site forensic studies undertaken.

Keywords

Deck Panel, Stay-In-Place Form, Precast Panel, Prestressed

1. Introduction

Deck panel bridges were constructed in Florida from the mid 70's to the early 80's; cast-in-place decks were originally planned. During construction, a change was made to use a precast, composite deck panel option, which consisted of a 90-100 mm thick precast panel, placed from girder to girder, over which a 90-100 mm cast-in-place slab deck was cast (Fig. 1). These two elements were intended to act as a composite deck system under live and superimposed dead load.

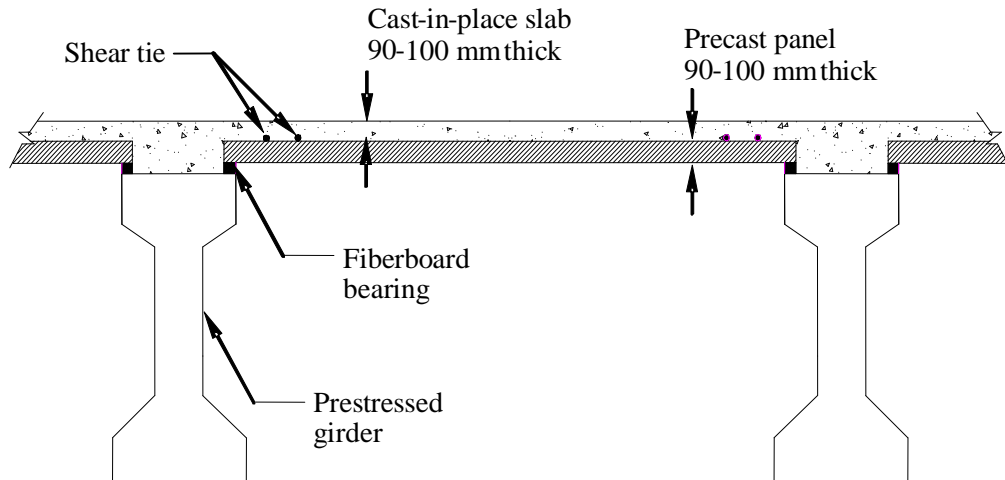

Figure 1: Cross Section of Precast Prestressed Panel Deck

This method of bridge deck construction gained enormous popularity because it eliminated the need for formwork in the field, which in turn reduced the amount of cast-in-place concrete by approximately one-half. It was a process that saved time, labor, and cost. Approximately 200 precast deck panel bridges were built in Florida. A large number of these bridges are located in the central region of the state along interstates I-4 and I-75 connecting Tampa to Daytona on the east coast and Naples in the south.

Deck panel bridges have an inherently greater propensity for cracking because of the presence of vertical joints between panels and cast-in-place concrete that can lead to reflective cracking even in regions of low stress. Such cracking can also be exacerbated by longer term differential shrinkage and creep effects. Nonetheless, deck panel bridges have performed well in service and are the preferred construction mode in Texas (Hays and Tabatabai, 1985).

Under federal law, all bridges are required to be inspected once every two years. During routine inspection even in newly constructed bridges, deficiencies in the form of cracking and spalling were detected. The first sign of deficiency usually appeared in the form of a crack on the deck top surface that can be parallel (Fig. 2A) or perpendicular (Fig. 2B) to the traffic direction reflecting the longitudinal and transverse panel edges. Spalls subsequently develop (Fig. 2C). Cracking can also occur on the deck underside. Underside transverse cracks (Fig. 2D) generally appear in the center and on the ends of the panels and radial cracks appear on the edges. Underside cracking is more hazardous, because unlike the visible deck top cracks, decks are rarely viewed from the bottom unless a formal inspection is being conducted.

Once a spall is formed, and left unattended, it starts expanding in extent as well as depth. Sometimes due to heavy or even moderate rains, over a weekend, spalls have gone down to the exposed steel category. In extreme cases spalls deteriorated into holes that went all the way through the bridge deck in a matter of days.

Because of such localized failures, the intent of the Florida Department of Transportation is to ultimately replace all deck panel bridges. In the interim period, a research program was initiated to help develop a rational system for prioritizing this replacement. This paper provides a brief overview of on-site forensic studies that were conducted as part of this effort.

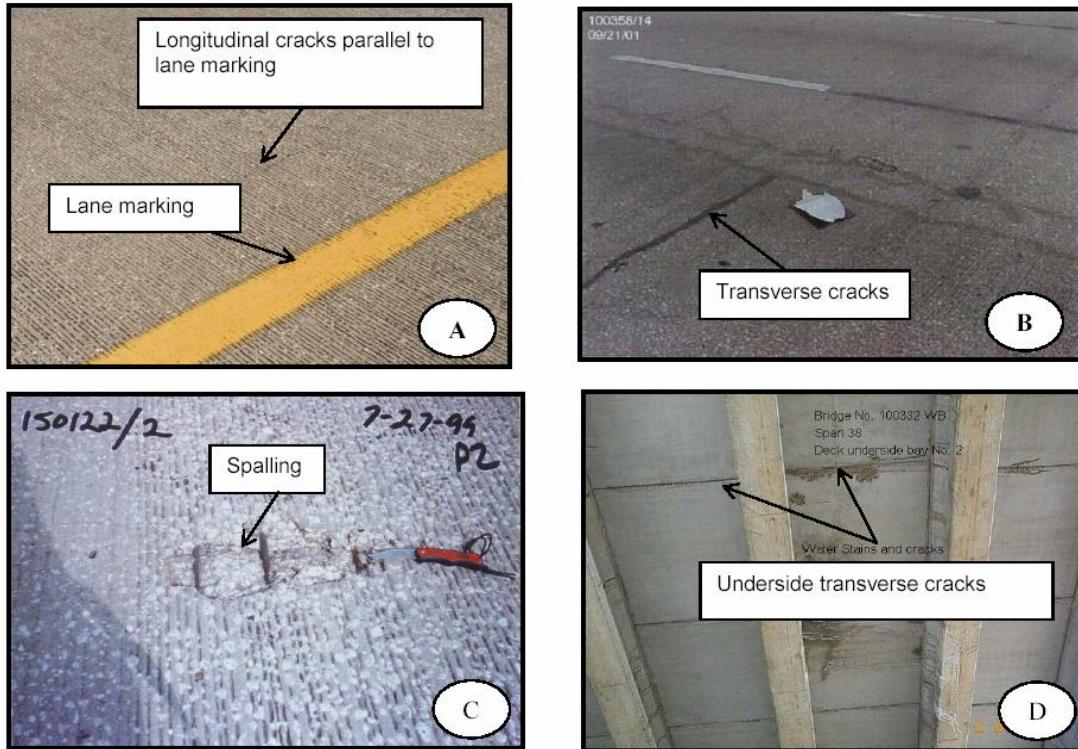

Figure 2: Cracking in Deck Panel Bridges

2. Previous Research

In 1982, Florida Department of Transportation asked the University of Florida, Department of Civil Engineering, to perform an in-depth study as to why the decks were prematurely cracking along the beams. The report (Structures and Materials Research Report No. 85-1 by Hays and Tabatabai, August 1985) concluded that the primary problem with the design was the placement of the panels onto the adjacent girders supported only by fiberboard bearing material (see Fig. 1), instead of using a solid, positive bearing material.

In the conclusion of the University of Florida report, the authors stated that for these decks, "The fatigue life is substantially less than that of conventional bridge decks or panel bridges with positive bearing at the ends of the panels." The report also said, "maintenance costs will probably be more than those of deck panel bridges that have positive bearing." Based on these findings, the Department implemented changes to improve the performance of the bridges, e.g. replacing fiberboard with epoxy.

3. Possible Causes for the Deficiencies

No recent study has been made to determine the causes for the deficiencies because construction records were unavailable to review the design or construction techniques that were employed. However, on-site observations indicate that the deck panel deficiencies could be associated with the various following factors:

- Lack of or deterioration of proper fiber board bearing material placement between the panels and the supporting beams may result in point load transfer and cracking of the panel and deck top.
- Shear connectors between the beams and the decks and between the panels and the cast-in-place deck tops may not be effective, if improperly designed or damaged during travel to or placement at the site.
- Although the widespread characteristics of the deficiencies raise concerns about the design of this type of composite deck system, construction deficiencies could also affect the performance of the deck. Workmanship, improper reinforcement placement, concrete placement temperature, early traffic allowance, curing methods, concrete quality, and other construction factors can have a significant impact on the durability of these structural systems.
- Localized repairs may have resulted in damage to sound adjacent sections that eventually cracked and spalled, thus creating a vicious cycle of spalling- repair-spalling.
- Span and panel flexibility: Panels with long bay or bridge spans appear to exhibit more deficiencies than panels with short spans. A panel bay span is the center to center distance between adjacent girders (girder spacing), which is perpendicular to the direction of traffic. Also panels on steel girders as opposed to concrete AASHTO girders tend to display more deficiencies, possibly due to their greater flexibility.
- Load fatigue related to the increase in ADT counts, speed limits, and age of the bridges may also be responsible, since the deficiencies have increased in number and severity in recent years on the high ADT count bridges. (The low ADT count bridges exhibit significantly fewer or no severe deficiencies.)
- Rainfall is a contributing factor to the acceleration of the deterioration as pressurized water expands the cracks and spalls.
- The Southbound I-75 bridges were completed first and facilitated the construction of the Northbound bridges. They may have been opened to traffic earlier than should have been recommended.

4. Forensic Study

Previous research identified the important role played by the fiberglass bearing. However, not all the panel deck bridges displayed similar distress: when the USF research team inspected 67 deck panel bridges, 39 were found to be in good condition. Only 7 were in poor or serious condition. Thus, there was a need to determine the reason for this anomalous performance (Gualtero et al., 2005).

During the course of the research study, several deck panel bridges were replaced. Not all of these bridges were replaced because of their deteriorated condition, but some were replaced as part of bridge widening. As a result the research team had the opportunity to examine the construction of bridges in different states of disrepair.

The aim of the investigation was to compile a photographic record of the deterioration that could be used in developing a rational failure model. This would allow the development of a deterioration model that could be used for the prioritization process. As this was not originally part of the research project, the forensic study had to be minimally invasive so that it did not interfere with the contractor's work. In essence, the forensic inspection had to provide the maximum information without disrupting the contractor's operation.

On site investigations were conducted for eight bridges that were all located on the major north-south interstate I-75 that links Michigan to Florida. Given the importance of these highways, replacements were carried out with great rapidity. As a result, forensic evaluation was generally based on a study of panels that had already been removed (Fig. 3) or inspection of panels in place after adjoining panels had been removed. In rare instances, panels that had been identified as problematic prior to removal could be examined on site.

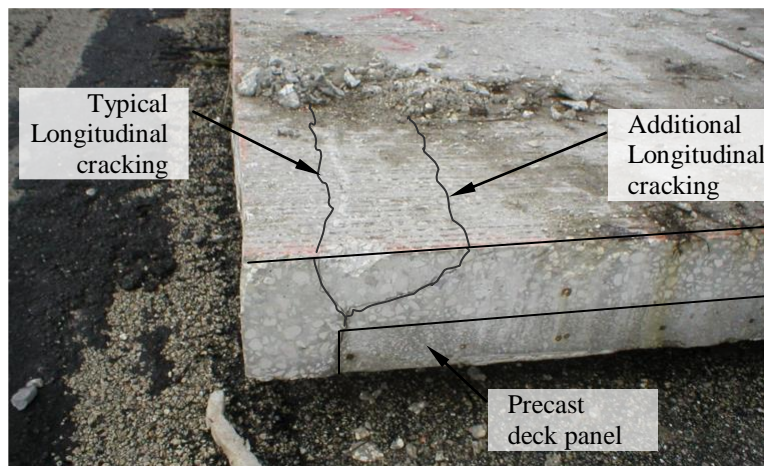

Figure 3: View of Cracking in Retrieved Panel

Despite these limitations, sufficient information was obtained to allow the development of a progressive deterioration model. Additionally it also permitted actual support conditions for deck panels to be examined. This showed that contrary to widely held views that all deck panel bridges in Florida were supported on fiberboard panels, bridges that performed well had been constructed differently. In these bridges, the deck was supported on a 25 mm to 40 mm mortar bed (Fig. 4). This permitted wheel loads to be transferred by the entire slab not just the precast panel.

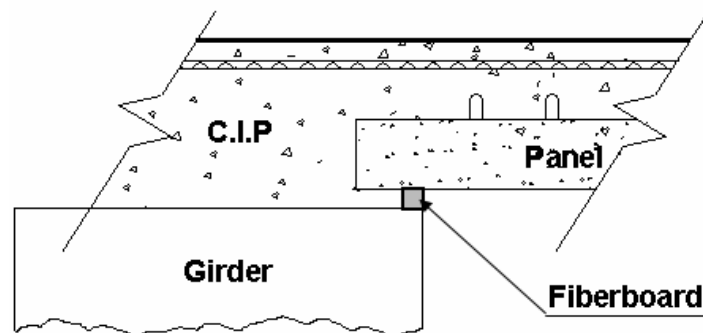

Figure 4: Correctly Constructed Deck Panel Bridge Deck

While the performance of deck panel bridges with mortar support (Fig. 4) was better than those with only fiberboard support (Fig. 1), they also displayed longitudinal cracking on the deck. However, these cracks did not further develop into spalls. In isolated cases, deck panel bridges with mortar support also developed serious spalls. Forensic study of these regions revealed that this was a result of poor construction which resulted in inadequate mortar support under the panel, resulting in the panel being supported mainly on the fiberboard (similar to Fig 1). This was caused due insufficient overhang of the panel from the fiberboard, and also due to incomplete flow of mortar under the panel. Recent design standards for deck panel construction (Merrill, 2002) address this by specifying a minimum of 38 mm overhang of the panel from the fiberboard and a minimum 6.25 mm thick gap between the girder and the panel to enable adequate flow of mortar under the panel (Fig. 6).

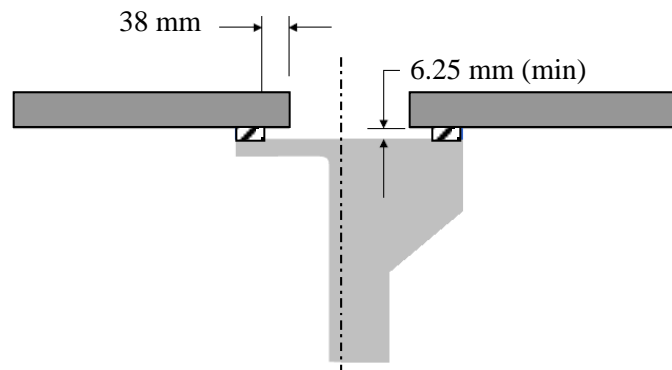

Figure 6: Texas DOT Standards for Deck Panel Bridge Construction (Merrill, 2002)

5. Conclusions

Construction plays a critical role in the performance of any structure. In the case of deck panel bridges built in Florida, the precast panels in many instances were supported entirely on fiberboard (Fig. 1). This type of construction led to extensive cracking, spalling and localized failure. However, if the deck were correctly constructed (Fig. 4) such problems would not occur. Texas has 1668 such bridges and similar problems are unknown.

This paper provides a brief overview of forensic studies undertaken to develop a degradation model that combined on specialized inspection was used to prioritize replacement of deck panel bridges in Florida. The study recommended fewer than 50% of the decks to be replaced based on the performance of the decks. The implementation of these findings will result in significant savings to the tax payer.

6. Acknowledgements

This study was performed in cooperation and funding from the State of Florida and US Department of Transportation. The assistance and guidance of Mr. Jose Garcia and Mr. Steve Womble from the FDOT is gratefully acknowledged. The opinions findings and conclusions expressed in this publication are those of the authors and not necessarily those of the Florida or US Department of Transportation

7. References

Gualtero, I., Pai, N., Sen, R., Alvi, A., Deshmukh, G., Mullins, G. and Ayoub, A. "Replacement

Prioritization of Precast Deck Panel Bridges”. Final Report Contract BC 353 RPWO#48, University of South Florida, March 2005, 303 pages.

Hays, C. and Tabatabai, H. “Summary of Research on Florida Precast Panel Bridges” Structures and Materials Research Report No. 85-1, University of Florida, Department of Civil Engineering, August 1985, 77 pages.

Merrill, B, “Texas’ Use of Precast Concrete Stay-In-Place Forms For Bridge Decks”, Concrete Bridge Conference, 2002.