

Polymer Window Subframe for Passive Houses

Libor Matejka, Jan Pencik

*Faculty of Civil Engineering, Brno University of Technology, Brno, Czech Republic
matejka.l@fce.vutbr.cz, pencik.j@fce.vutbr.cz*

Abstract

The increasing quantity of waste materials is associated with continuously increasing need for their recycling and reuse. An important subgroup of waste materials is polymers. Selected polymers with suitable thermal-technical and physical-mechanical properties can be used with advantage also in civil engineering. Application of recycled polymers suitably supports decreasing of energy exigency and thus the area of sustainable engineering.

One of current trends of energy savings in civil engineering is the proposal and construction of low-energy and passive houses. This new concept is associated with the arisen need to solve originated details both in terms of the design and material. On the basis of analyses details of critical areas were outlined. In the place of discovered imperfections design solution with proposal of products made of recycles eliminating the imperfections of the design was designed. The issues are processed within the research intent labelled "Progressive construction materials using secondary raw materials and their influence on the life span of the civil engineering structures", which is now being solved at the Faculty of Civil Engineering of the Technical University in Brno, Czech Republic.

Keywords

Waste, Polymers, FEA analysis, Window, Sub-frame

1. Introduction

One of the outputs of the research is the design of new product made of recycled raw materials – sub-frame intended for passive houses and low-energy houses. This product allows for location of fill-up of openings, window for example, in the place of thermal insulation of cladding. The shape of the product respects both the requirements for the detail of the contact of the fill-up of the opening and cladding, as well as the requirements for functionality and stability for the entire service life. To verify functionality the product prototype are subject to short-term and long-term measurements.

Recognition of waste polyethylene material characteristics is decisive for possible application of this material in building products. In addition knowledge of this material is essential for quality of the whole structure in which the material is applied. It also contributes to broader options of mathematic models and therefore time and cost saving related to testing of products as physical models. Conclusions of the material characteristics research brought rather interesting findings. HDPE material almost does not lose its properties by types recycling. The identified values of the individual material characteristic are almost equal to generally acknowledged values of virgin HDPE material. High quality material may be obtained from high quality recycling technology. Certainly, material values differ since number of HDPE modifications exist, however the average values are close to the virgin material values. Material characteristics values vary with worse recycling technology (mostly degrade) due to impurities and

presence of other materials particles. For the purpose of manufacturing products intended for construction industry it is recommended to choose the best available recycling technology and always determine the most important material characteristics as reference values if material from other waste processor is used. In case of a material with normal flammability it is possible to increase its fire response class to B quite easily by using a burning retardant while retaining similar material characteristics as the non-retarded material. This class enables material application in buildings. Bulk weight of retarded materials is approximately 20 % higher, the heat conductivity coefficient is 11% lower and in case of mechanical properties it achieves values which are approximately 10% lower with the exception of elasticity coefficient which is 10% higher. Another interesting conclusion of the material characteristics research is production technology dependence and recycled polyethylene material characteristics. In case of compression molding boards values of heat conductivity coefficient and rigidity values are lower than in case of material produced by extruding. Stress-rupture module values are approximately 30 ÷ 40 % higher for the retarded material comparing to non retarded one, where the stress-rupture curve corresponds to virgin polyethylene. Compression test documents that pre-stressing given to the material by compression is positively reflected in the elasticity module. This may be increased by up to 15 % and positively reflected in material bearing capacity.

Based on the knowledge of the recycled polyethylene material the design and prototype of a product for civil engineering is made – sub-frame for opening fillups in passive houses. Sustainable development is contributed not only by the saving in energy of application of the above product, but also the use of waste HDPE and thus extension of its life cycle.

2. Recycled Plastic Subframe for Window Opening Fillups in Passive Houses

The aim of the proposal of the new product is especially the effort to satisfy the requirements for detail of installations of opening fillups and deficiencies of current methods of installations of the opening fillups. New product is proposed, made of recycled raw materials – sub-frame intended especially for passive houses and low-energy houses. The shape of the product respects both the requirements for the detail of the contact of the fill-up of the opening and cladding, as well as the requirements for functionality and stability for the entire service life. The recycled plastic material for production of sub-frame is HDPE – regranulate. Based on the test results and experimentally discovered mechanic characteristics a new prototype of sub-frame is manufactured.

The product consists of joined boards of constant thicknesses forming a window ledge, window reveal and window head (Figure 1a). Inside the frame the boards are installed vertically and around the frame and form an internal reinforcing frame (Figure 1b), which is also intended as contact surface of the opening fillup, i.e. opening fillup frame. Concurrently this internal reinforcing frame forms a clear and precise contact, which prevents origination of leakages and associated problems with air tightness and water resistance. The contact concurrently allows for positioning of the fillup of the openings with regard to the position of the thermal insulations without significant changes to thermal-technical parameters. Thermal technical properties of the sub-frame made of recycled plastic material, influence of the recycled plastic sub-frame on inner climate of the room, influence of the position of the opening fill-up with regard to composition of the frame and influence of the thickness of the board of the recycled plastic sub-frame on thermal-technical properties of the structure was the subject of the survey. On the outer side of the main frame the boards are installed vertically and around the frame and form an internal reinforcing frame (Figure 1c). This outer reinforcing frame serves for precise definition of the position of the product in composition of the cladding and concurrently serves for termination of the airtight layer of the building envelope. Both these frames, i.e. inner and outer (Figure 1b, 1c) concurrently contribute to an increase of stability and strength of the entire product. The recycled plastic sub-frame is to improve the static behaviour completed in the area above the window head with reinforcing elements of rectangular, triangular or trapezoid shape (Figure 1d). Static action, dimensions of the recycled plastic sub-frame

depending on the size of the opening and anchoring methods were thoroughly analyzed. The recycled plastic sub-frame is universal and can be used on the basis of static assessment for any structural composition or opening size or possibly for their combination. The expected maximum size of the opening is 2500×2500 mm. The recycled plastic sub-frame concurrently maintains the main advantages of standard sub-frames, which are the following:

- possibility installation of the opening fillup after finishing the plasters,
- easy assembly of the opening fillup from the building interior, which means no scaffolding is needed,
- improvement of thermal technical properties of the opening fillup frame in connection with rebated jumb completed with thermal insulation (Matějka *et al.*, 2007, Šinogl *et al.*, 2007).

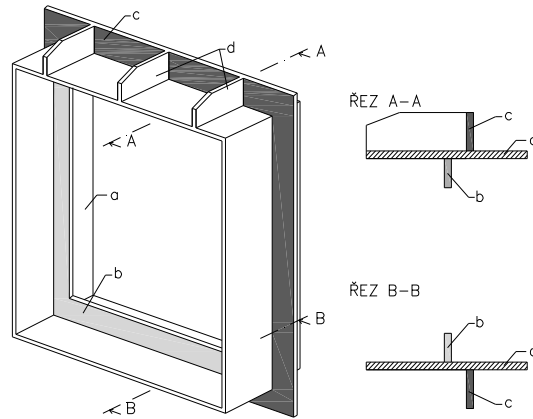

Figure 1: Recycled Plastic Sub-Frame – Axonometric View from the Exterior, A - Perimetral Frame, B – Inner Reinforcing Frame, C - Outer Reinforcing Frame, D - Reinforcing Elements

Location and anchorage of the recycled plastic sub-frame in the structure of the cladding of the passive house, insertion of the opening fill-up into the recycled plastic sub-frame and creation of rebated jumb by inserting thermal insulation is shown in the following figures.

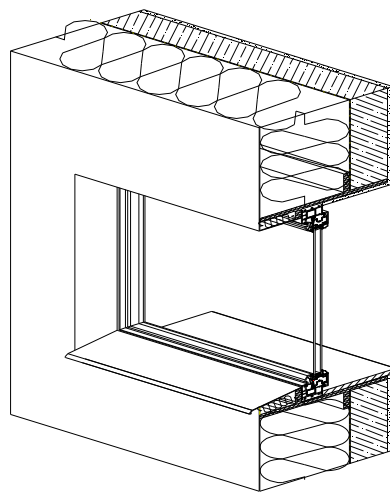

Figure 2: Recycled Plastic Sub-Frame – Axonometric Section View of the Composition of the Structure From Outside

The subframe structure is anchored in the load-bearing structure of the cladding of the building by means of anchor bolts. The entire recycled plastic sub-frame is anchored in the place of reveal (the most suitable position and distance of the anchoring elements was optimized) and in the place of window head. In the place of window head the sub-frame is anchored from below and can be anchored from side via outer reinforcing frame. Mathematical modelling of the influence of the position of anchoring elements in height H and width of the head B are made.

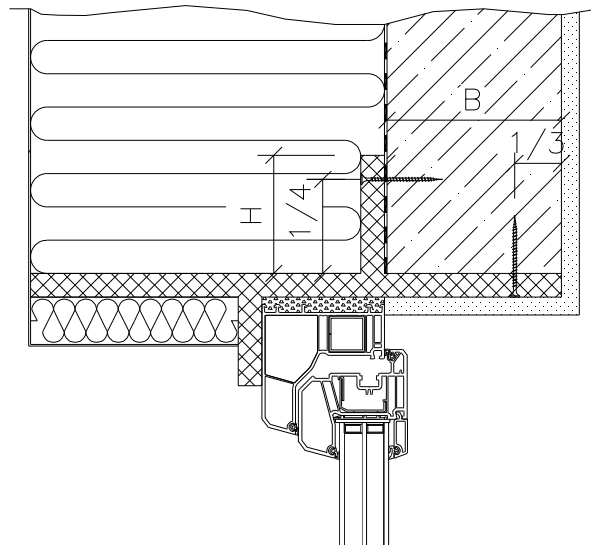

Figure 3: Marking of Location of the Anchoring Elements in the Opening Head

Thermal and hydrotechnical action of the recycled plastic sub-frame, its structural details, sealing and anchoring are described in the following chapters.

3. Optimization of the Detail of Connection of the Subframe to Window Frame

The detail of connection of the sub-frame to window frame is complicated in terms of installation and functionality. The intention is to optimize this detail and select the most suitable combination of material and their location in the detail. In this aspect we established cooperation with leading global manufacturer of plastic windows, the Rehau Co. In cooperation of with experts of the given issues we developed a new window sill profile for the existing window system Rehau clime-design. This new window sill profile fully respects the shape of the sub-frame and concurrently allows for seamless use of the window and uses concurrently used window profiles. The window sill profile is elevated compared to those standards used to allow for passage of the inner reinforcing profile of the sub-frame. For the same reason concurrent adjustment of the drip ledge is made. It is extended in order to make the break form a space for location of inner reinforcement profile of the sub-frame and concurrently to enable efficient plating of the sill over the thermal insulation forming rebated jumb. The space above the drip ledge is perforated with certain spacing and allows for drainage of possible humidity originated in the interspaces between the frame profile and sill profile. Perforated opening are in the exterior covered with laths preventing introduction of water and wind from the exterior to the interspaces. In solving the details the emphasis is put especially on thermal and acoustic protection. Solution of gaps and elimination of thermal bridges is also emphasized. The window is anchored to the frame mechanically using anchoring means and between the window and sub-frame there is a dilatation to adapt to temperature changes and prevent transmission of load onto the window.

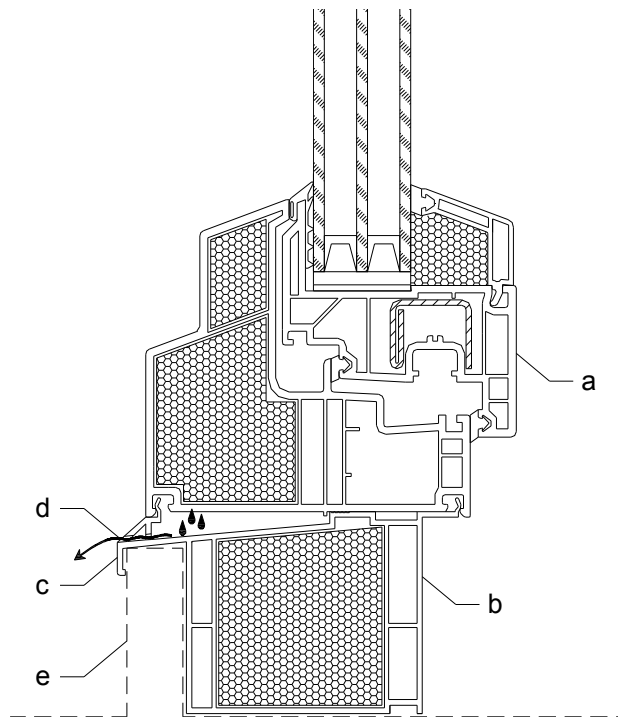

Figure 4: Window Profile for Passive Houses Optimized for Use in Combination with Recycled Plastic Sub-Frame: A) Frame Profile, B) Adjusted Window Sill Profile, C) Extended Part of the Drip Ledge of the Window Sill Profile, D) Window Sill Profile Perforated to Remove Humidity, E) Sub-Frame Position

Connecting joints in the detail of the window installation must be especially carefully ensured. In principle the detail of sealing of the connection joint can be divided in three functional levels:

- functional level 1 : inner sealing provides for separation of the climate in the room from outer climate,
- functional level 2 : anchoring to the perimetral casing structure and acoustic and thermal protection,
- functional level 3 : outer sealing against atmospheric effects.

Functional levels combine according to the principle of higher diffusion resistance on the interior side than the exterior one. The sealing of the joint from the exterior is carried out in two stages. The first level using structural components prevents penetrating of rain and diverts the water downwards in a controlled manner. The second level is carried out as wind protection.

The sealing of the joint between the window sill profile and recycled plastic sub-frame can be executed in two manners. The first one consists in the insertion of precompressed impregnated single sided adhesive polyurethane foam tape (for example Illbruck Illmond 600-20/2 mm). The second one consists in the insertion of water resistance and highly steam permeable polypropylene foil (for example Illbruck exterior window foil). The foil is applied on impregnated surface in case of concrete or to perfectly decreased surface in case of plastic.

The functional level no. 2 must be fulfilled with thermal insulation material. The most frequently used material for these applications is PUR foam with the thermal conductivity coefficient $\lambda = 0.04 \text{ W m}^{-1}\text{K}^{-1}$.

The sealing of the joint in the interior can be done by inserting airtight and steam non-permeable polypropylene foil (for example Illbruck interior window foil). The foil is applied on impregnated concrete surface in case of plastic on perfectly decreased surface.

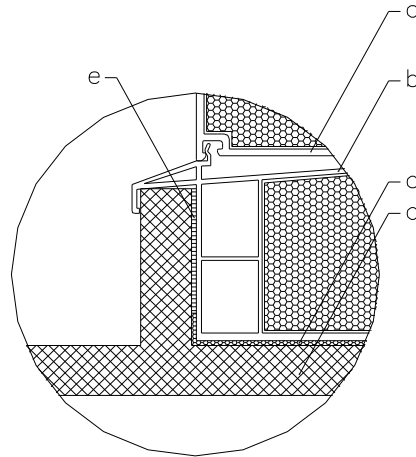

Figure 5: Sealing of Joint in the Exterior Using Precompressed Impregnated Single Sided Polyurethane Foam Adhesive Tape: A) Window Profile, B) Window Sill Profile, C) PUR Foam, D) Recycled Plastic Sub-Frame, E) Polyurethane Foam Tape

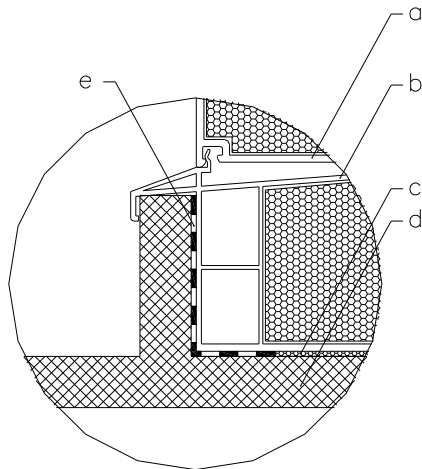

Figure 6: Sealing of Joint in the Exterior Using Water Resistant and Highly Steam Permeable Polypropylene Foil: A) Window Profile, B) Window Sill Profile, C) PUR Foam, D) Recycled Plastic Sub-Frame, E) Exterior Tape

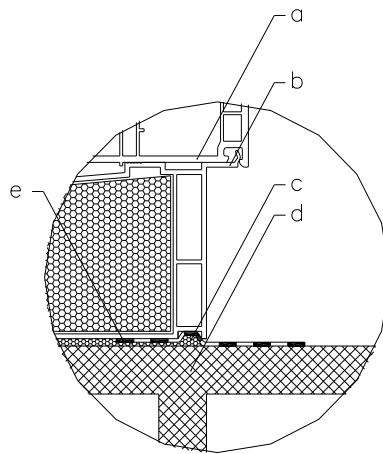

Figure 7: Sealing of Joint in the Interior Using Airtight and Steam Non-Permeable Polypropylene Foil: A) Window Profile, B) Window Sill Profile, C) PUR Foam, D) Recycled Plastic Sub-Frame, E) Interior Tape

The window detail executed according to these principles and with adjusted window sill profile for the possibility of installation on the sub-frame constitutes a sealed assembly meeting high demands of the passive houses. The function of the detail from adjusted profiles in terms of thermal technique is shown in the following chapter.

4. Thermal-Technical Assessment of the Window Installation Detail

Detail of installation (Matějka *et al.*, 2007) of the newly developed window profile and its coaction with the recycled plastic sub-frame in detail at the sill is subject to thermal-technical assessment. To compare the thermal-technical properties improved by the sub-frame there is a second version of the detail in window sill. This version does not have rebated jumb and sub-frame. The results of comparison are shown in Table 1. The lowest surface temperatures are calculated on the window frame surface and in contact of the window with the window sill.

Table 1: The Lowest Inner Surface Temperatures of the Frame of the Newly Developed Profile of Plastic Window for Passive Houses and Application in the Sub-Frame

Detail version	Lowest surface temperature °C	
	contact	on frame
Sub-frame, rebated jumb	19.207	18.305
No sub-frame and not rebated jumb	19.133	18.283

The results, on which it is possible to make mutual comparison of the temperature progress in the structure including surface temperatures in the selected points of the interior, are shown in Figure 8. The results imply positive influence of the rebated jumb on the lowest surface temperature in the place of contact of the window sill profile with the sill. The improvement is approximately 0,1° C. The frame influence is less significant. This phenomenon is caused by significant increase of window sill profile even in the area, where it is filled with thermal insulation. This massive window sill profile also contributes to increase of surface temperatures in the interior compared with non-modified window sill profile normally used for passive houses. The difference in surface temperatures compared to non-modified window frame is thus more significant. The combination of the modified frame and sub-frame

significantly influences the surface temperatures in the interior and thus contributes to improvement of the thermal comfort in the interior of the passive house and thus decreases the costs of its heating.

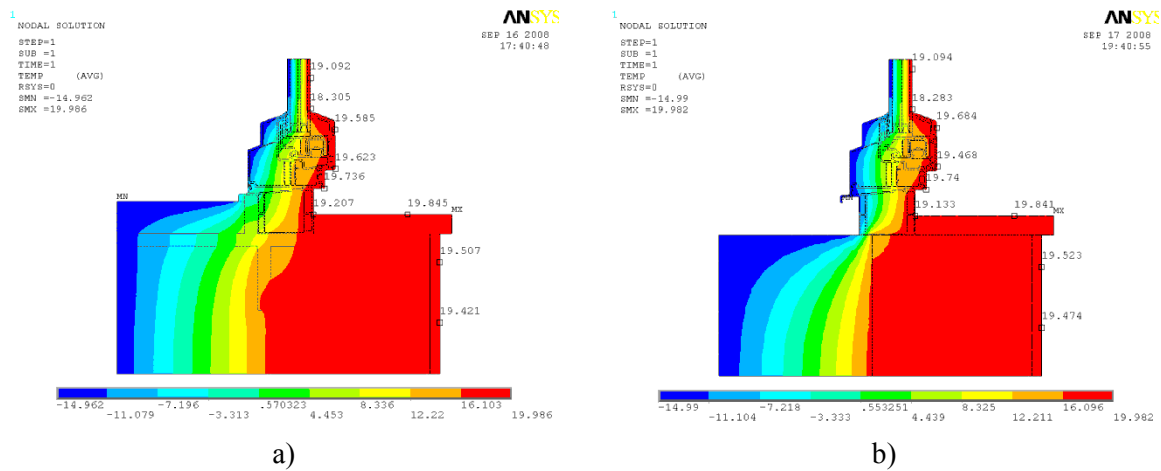

Figure 8: Results of Mathematical Modelling of Temperature Field in the ANSYS Computation System: A) Detail of the Sill with Sub-Frame, B) Detail of the Sill without Sub-Frame

5. Concluding Remarks

Properties of such frame have been verified in mathematic models and its thermal technique and static functionality has been documented. It has been proved that the frame is capable to transmit load resulting from its own weight and external load imposed on it reliably even during the times with reducing stress-rupture module values. The frame is also suitable for 2500×2500 mm large doors and windows. As concerns thermal technique the frame contributes to improved function of window installation and seal with wall structure. There is a positive influence of combination of rebated jamb with thermal insulation, where improvement of the lowest internal surface temperature by up to 1.10 °C can be observed. Another benefit of the installation frame product made of recycled polyethylene is its variability in window position in the wall structure. Having thermal technique in mind the window position within the thermal insulation thickness is most suitable. However it is problematic to use this position with current options of window installation and it results in creation of thermal bridges. The installation frame enables window installation within the thermal insulation thickness and therefore contributes to increased thermal comfort inside a room. An interesting finding, resulting from mathematic model of thermal technique, is the most suitable window position in the external wall. It has been documented that the most beneficial position, from thermal technique and sun exposure point of view, is approximately in the middle of thermal insulation. Advantage of the frame, contributing to economic demands of passive houses, is its easy installation, possibility to apply plaster coat after window installation, perfect air-proofness and frame variability.

6. Acknowledgements

This article was elaborated as part of Research Intention MSM 0021630511.

7. References

- Šinogl, J., Matějka, L. and Pěňčík, J. (2007). “Řešení kritického detailu kotvení výplní otvorů u pasivních a nízkoenergetických domů” 2. mezinárodní konference Budovy a prostredie, ISBN 978-80-227-2759-4, STU-Vydavateľstvo STU, Bratislava, Slovak Republic.
- Matějka, L., Pěňčík, J. and Šinogl, J. (2007). “Osazovací rám pasivního domu z druhotných surovin”, Česko – Slovenská konference Experiment 2007, ISBN 978-80-7204-543-3, Brno, Czech Republic.